

ENE 411 - ENGINEERING LAB II

EXTENDED SURFACE HEAT TRANSFER EXPERIMENT

OBJECTIVE

Objective of this experiment is to understand and investigate steady-state one-dimensional conduction from an extended surface, a fin. For this purpose, temperatures on a cylindrical rod heated from one end will be measured at equal intervals. Given overall heat transfer coefficient from the surface, temperature distribution and total rate of heat transfer will be calculated and compared with the measured values.

THEORY

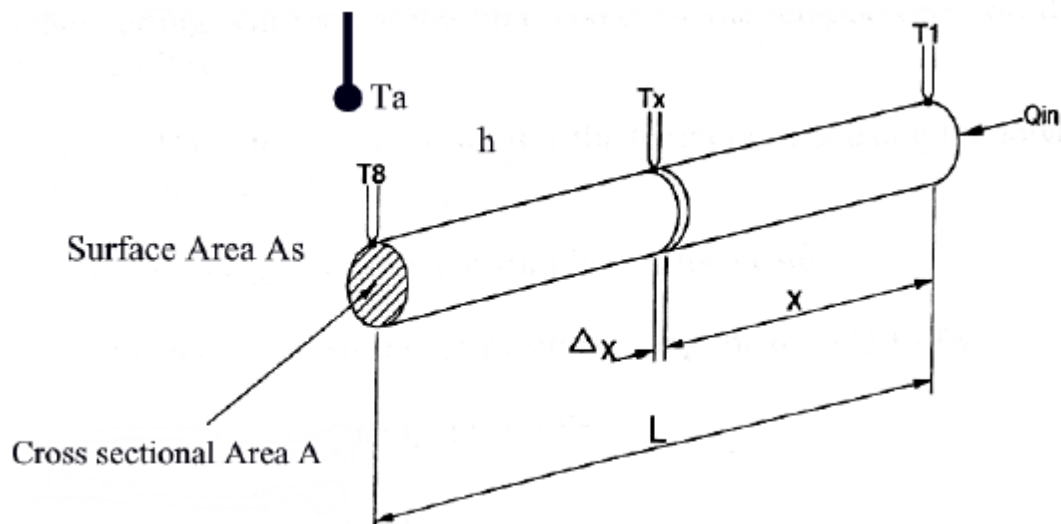

A pin of length L diameter D and cross-sectional area A (Perimeter P) and thermal conductivity k is heated at one end. It has a total surface area A_s and is in an ambient at temperature T_a . Due to the heat input from one end, the temperature of the bar is raised above that of the surroundings and heat is convected and radiated away from the surface. As the heat input is from one end only and the bar is thermally conductive, the temperature will vary along the bar from T_1 at the hot end to T_2 at the far end. It is assumed that the bar is sufficiently long for there to be negligible heat transfer from the tip. At any distance x from the heated end the temperature of the material is T_x .

The system is in steady-state, so the energy entering from the base of the cylinder does not stored within the material; it is removed from the system by convection and radiation. Therefore, it can be written that

$$q_b = -kA_c \frac{d^2T_x}{dx^2} = (h_r + h_c)A_s(T_a - T_x) = q_{r+c} \quad (1)$$

where q_b is the rate of heat transfer from the base ($x=0$), q_{r+c} is rate of heat removed by convection and radiation. A_c is the cross-sectional area and A_s is the surface area of the fin. h_r and h_c are the heat transfer coefficients of radiation and convection respectively. Although heat transfer coefficients depend on the temperature of the surface, following simplified relations can be used for estimation of h_r and h_c .

For radiative heat transfer between a cylindrical surface and environment, it can be written that

$$h_r = \sigma \varepsilon \frac{(T_m^4 - T_a^4)}{(T_m - T_a)} \quad (2)$$

where σ is Stefan-Boltzmann constant, ε is emissivity of the cylindrical surface, which can be taken as unity in this experiment, and T_m is mean surface temperature of the cylinder.

For natural convective heat transfer from a cylindrical surface, following empirical relation can be used.

$$h_c = 0.042 \frac{(T_m - T_a)^{0.25}}{D} \quad (3)$$

where D is the diameter of the cylinder.

Replacing $(h_r + h_c)$ with an overall heat transfer coefficient h and rearranging equation (1), it is possible to write the following differential equation to describe conditions along the bar.

$$\frac{d^2T_x}{dx^2} - \frac{hP}{kA_c}(T_x - T_a) = 0 \quad (4)$$

where perimeter P is equal to

$$P = \frac{dA_s}{dx} \quad (5)$$

where A_s is the area of the cylinder with the length of x . To transform equation (4) into a homogenous equation, introduce $\theta \equiv (T_x - T_a)$. The equation (4) becomes:

$$\frac{d^2\theta}{dx^2} - \frac{hP}{kA_c}\theta = 0 \quad (6)$$

If we introduce $m^2 \equiv hP/kA_c$, equation (6) becomes:

$$\frac{d^2\theta}{dx^2} - m^2\theta = 0 \quad (7)$$

General solution of the equation (7) can be written as;

$$\theta(x) = C_1 \cosh(mx) + C_2 \sinh(mx) \quad (8)$$

Where C_1 and C_2 are constants. Boundary conditions must be written to find the constants. From the experimental set-up, the following boundary conditions may be applied;

$$\theta(x)|_{x=0} = \theta_b \text{ (base temperature is defined – measured value)} \quad (9)$$

$$-kA_c \frac{d\theta}{dx} |_{x=L} = q_t = 0 \text{ (the tip of the cylinder is insulated – the cylinder is long)} \quad (10)$$

where q_t and θ_b are rate of heat transfer from the tip and temperature difference between the base and ambient respectively. By applying the boundary conditions, it can be shown that

$$\frac{\theta(x)}{\theta_b} = \frac{\cosh(mL - mx)}{\cosh(mL)} \quad (11)$$

where $\theta_b = T_b - T_a$, (T_b is the temperature at the base), and $m = \sqrt{hP/kA_c}$.

After solution for the temperature distribution is written, total rate of heat removed by the fin can be found by employing Fourier's law of conduction at the base, since heat transferred away by the fin is equal to heat conducted into it by the heater.

$$Q = -kA_c \frac{d\theta(x)}{dx} |_{x=0} = kA_c \theta_b m \tanh(mL) \quad (12)$$

where Q is total rate of heat removed by the fin.

It is also possible to find conduction coefficient of a material by looking at the temperature distribution with a known rate of heat input to the fin. Rearranging the equation (12) as the following and using measured Q values input.

$$k = \frac{Q}{A_c \theta_b m \tanh(mL)} \quad (13)$$

Conductive coefficient of a uniform cross-section fin made by an unknown material can be found by using equation (13).

EXPERIMENTAL SETUP

The Extended Surface Heat Transfer experimental set-up allows investigation of one-dimensional conduction from a fin. A small diameter metal rod is heated at one end and the remaining exposed length is allowed to cool by natural convection and radiation. This results

in a diminishing temperature distribution along the bar that is measured by regularly spaced thermocouples.

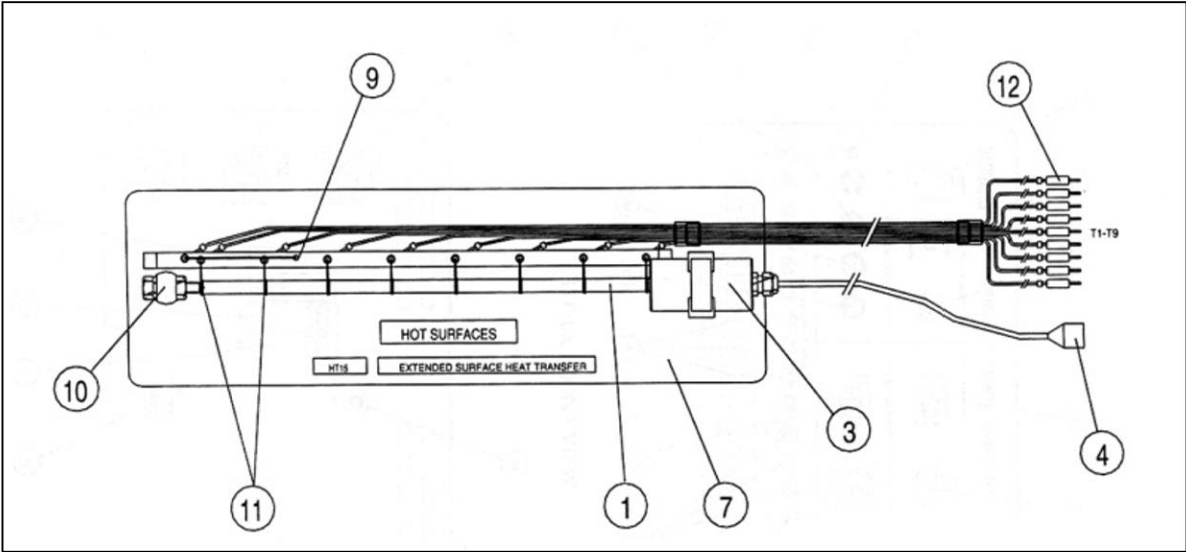

Figure 1: Schematic representation of the experimental set-up extended surface accessory

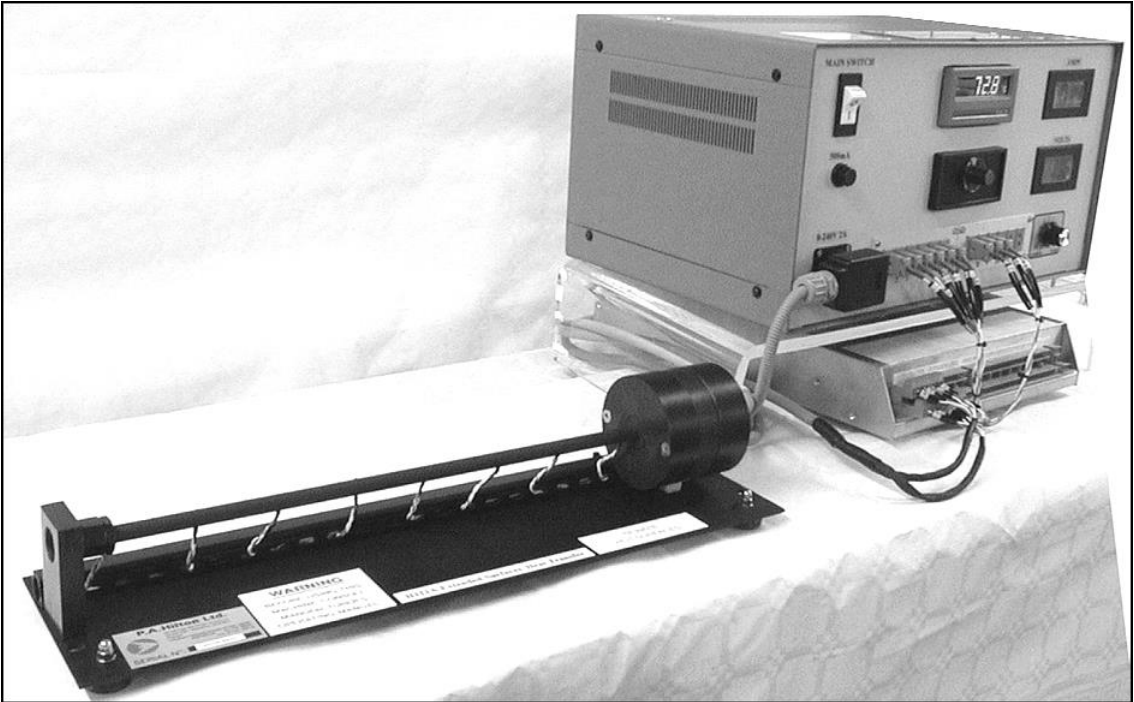

Figure 2: Experimental set-up composed of heat transfer unit and extended surface accessory

The experimental set-up comprises a heat transfer service unit and a 10 mm diameter brass rod (Figure.1-1) of approximately 350 mm effective length mounted horizontally with a support (Figure.1-6) at the heated end and a mounting steady (Figure.1-10) at the opposite end. Inside an insulated housing (Figure.1-3) is a 240V electric heater (Figure.1-5) in direct contact with the brass rod. The heater has a nominal power rating of approximately 30 Watts at 240V AC. The power supplied to the heated cylinder is provided by the Heat Transfer Service Unit through the power lead (Figure.1-4). The Heat Transfer Service Unit also allows the operator to vary

the power input to the heater by control of the voltage supply to the heater element. For safety purposes a thermostat (Figure.1-2) limits the maximum temperature of the heater to approximately 150°C. Eight thermocouples (Figure.1-11) are located at 50 mm intervals along the rod to record the surface temperature. These connect to the Heat Transfer Service Unit through the miniature plugs (Figure.1-12). The thermocouples are attached to the rod in order to minimize errors from conduction effects. An additional thermocouple (Figure.1-9) is mounted on the unit to record the ambient air temperature. In order to protect the thermocouples from damage all lead terminations are mounted firmly into trunking and conduit (Figure.1-8). The rod is coated with a heat resistant matt black paint in order to provide a constant radiant emissivity close to 1.

The dimensions and relevant thermophysical properties of the heated rod are given as:

Heated Rod Diameter D	= 0.01 m
Heated Rod Effective Length L	= 0.35 m
Thermal Conductivity of Heated Rod Material, k	= 121 W/m-K

EXPERIMENTAL PROCEDURE

1. Ensure that the main switch is in the OFF position.
2. Place the Extended Surface Heat Transfer accessory on a flat surface adjacent to the heat transfer service unit
3. Plug in the thermocouples (T1-T9) to their respective places in the Heat Transfer Service Unit.
4. Set the heater Voltage Controller on the front of the Heat Transfer Service Unit to zero (turn anti-clockwise)
5. Connect the power lead (Figure.1-4) from the heated cylinder to the 8-pole socket on the front panel of the Heat Transfer Service Unit.
6. Turn on the main switch, digital displays should illuminate.
7. Rotate the voltage controller to increase the voltage to that specified in the procedure for each experiment.
8. Allow the system to reach stability, and take readings. Note that due to the process of conduction and the small differential temperatures involved for reasons of safety the time taken to achieve stability can be long.
9. When the experimental procedure is completed, turn off the power to the heater by reducing the voltage to zero and monitor T1 until the rod has cooled. Then turn off the main switch.

OBSERVATIONS

Temperatures	
T1	
T2	
T3	
T4	
T5	
T6	
T7	
T8	
T9	

Heat Flux	
Voltage	
Current	

CALCULATED DATA

Calculation of temperature distribution along the fin:

Average Temperature (T_m)	Initial guess $(T_b + T_a)/2$	T_{m1}	T_{m2}		-
Distance from the base [m]	Temperature 1 st iteration (calculated)	Temperature 2 st iteration (calculated)	Temperature 3 st iteration (calculated)	...	Temperature (measured)
0.05					
0.10					
0.15					
0.20					
0.25					
0.30					
0.35					
Average Temperature (T_m)	T_{m1}	T_{m2}	T_{m3}		-

Note that you will use T1 as your base temperature.

Also note that you will need to make iterations in the calculations. In order to estimate heat transfer coefficients in equations (2) and (3), you will need mean surface temperature, T_m , (average surface temperature) of the cylinder, which you do not know (you cannot use measured temperature values except T1). You need to make an initial guess for average surface temperature, T_m (for example, mean of base and ambient temperature). Calculate h and m using this T_m value. Then find the temperature distribution function following the formulation in theory section. Write down temperature results in the table and calculate average surface temperature, $T_m (=T_{m1})$ value from the table. Compare it with your guess. If the difference between them is smaller than some pre-determined error, for example 0.1, then you can use this T_m value with a reasonable accuracy in your solution. If the difference is larger than 0.1, then using $T_m (=T_{m1})$ value calculated from table, repeat the calculation in theory section again and find a new temperature distribution function. Again calculating a new $T_m (=T_{m2})$ from the table, compare it with $T_m (T_{m1})$ value you have used; and check the error. Continue with the iteration until the error becomes smaller than 0.1.

Calculation of heat flux from the base of the fin:

Heat Flux at the base (calculated)	Heat Flux at the base (measured)

REPORT

In your report;

- Show your calculations and iteration steps explicitly.
- Plot measured temperature and the temperature distribution function. Compare them and comment on the differences if there is any.
- Compare measured and calculated heat flux at the base of the fin. Comment on the difference if there is any.
- Discuss possible sources of discrepancies in the experiment if there is any.
- Mention the assumptions made during the experiment and calculations, and discuss their effect on the results.